



Meeting Tough Demands

Laboratory facilities are among the most demanding environments in terms of dehumidification system requirements. Research labs require extremely high volumes of outdoor ventilation air, resulting in dehumidification loads of up to 10-times that of typical commercial applications. It is the job of the outdoor air system to minimize occupant exposure to particles and gases through the generous use of ventilation air and ducting that air away from contamination sources. With the Introduction of these large outside air volumes into the laboratory environment, humidity needs to be removed with high efficiency and reliability and trouble-free operation cannot be sacrificed.

MSP® answers these demands with our simple yet highly efficient dehumidification systems which employ no moving parts in the air stream. Our energy efficiency beats that of both desiccant wheel and heat-pipe technology, through the use of patented Multiple Small Plate design. In addition, desiccant

wheels are subject to breakdown and heat-pipe efficiency degrades significantly with lower temperature differences. MSP® heat transfer performance remains consistent, and significantly higher than that of heat-pipe technology (over 80% for MSP®, vs. under 40% for heat-pipe).

Environments requiring precise temperature control can also benefit by using a dehumidification system by removing the latent load from ventilation air. The sensible temperature controls coils can then operate much more predictably, not being subject to wide variations in sensible load due to outside air humidity.

With long operating hours, large outdoor air volume requirements, and air handling system reliability of primary concern, laboratory applications are best addressed using MSP® Dehumidification equipment.

Key Benefits & Features

- **Reliable** Simple Technology, No Moving Parts, Low Maintenance
- **Performs** Delivers consistent low dew-point temperatures
- **Sanitary** Full Draining, No Standing Water
- **Efficient** Cuts dehumidification operating costs by up to 50%
- **Fast ROI** Lower capital costs, Competitively priced
- **Versatile** Chilled Water and Refrigerant units
- **Advanced** Single unit provides dehumidification, sensible cooling, heating and ventilation air
- **Flexible** Horizontal, Vertical and Modular configurations for uses with space or access issues
- **Cutting-Edge Control Systems**

DEHUMIDIFIER WITH MSP® TECHNOLOGY

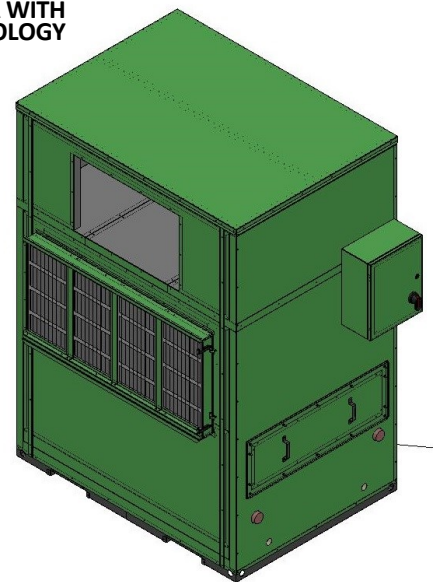

ABOUT MSP® TECHNOLOGY

MSP Technology is offered in a wide range of super-efficient, industrial grade equipment. Designed specifically for green applications, MSP products are engineered for high performance, guaranteed.

ABOUT MSP® AWG AND DEHUMIDIFICATION TECHNOLOGY

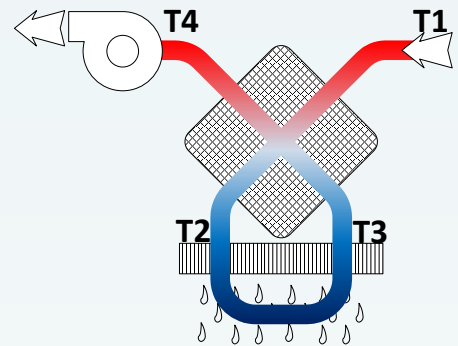

STEP 1 Warm, humid incoming air (T1) flows through the first pass of the plate type air-to-air heat exchangers for pre-cooling and initial dehumidification. This is accomplished by regenerative thermal exchange with the cooler air that is leaving the heat exchanger. (see step 3)

Advantage: Pre-cooling and dehumidification by regenerative thermal exchange are "free" and involve no additional equipment.

STEP 2 Pre-cooled air (T2) then passes twice over conventional cooling coils for final cooling and dehumidification.

Advantage: Pre-cooled and pre-dehumidified air can be treated much more efficiently, using smaller compressors that require as little as one-half the power.

STEP 3 The cool, dehumidified air (T3) is then drawn back through the opposite side of the heat exchanger where it absorbs some heat from incoming air (see step 1) and continues on to the building's HVAC system.

Advantage: No heating coil—and no energy penalty—needed to reheat the dehumidified air before it enters the conditioned environment.

Feature Highlights

High Efficiency

Cuts dehumidification operating costs by up to 50%

Low Maintenance

Direct Drive Fans, No belts and pulleys to adjust

No moving parts in airstream (except fan)

Versatile

Horizontal or Vertical configurations

chilled water or refrigerant

Sanitary

Full Draining, no standing water