

MSP[®] TECHNOLOGY IS SIMPLY THE MOST COST EFFECTIVE HUMIDITY CONTROL SOLUTION FOR EXPLOSIVE ENVIRONMENTS



Explosive and flammable process and storage

Special Care is required in maintaining suitable temperature and humidity conditions while also ensuring a spark free environment. Care must be taken to also ensure a well vented environment using equipment that will not cause ignition.

MSP is perfect for this environment

MSP is well suited for this application because of its ability to keep the most critical, spark producing components, out of the explosive environment. The condensing unit has electrical components that can spark, but the condensing unit in the MSP arrangement is placed outside the explosive environment. This leaves the dehumidifier fan as the only major component that must have explosion resistant design. AMCA Standard 99-0401 addresses the issue of

spark resistant construction (SRC) as type A, B or C, each having its own level of spark resistance to meet the requirements of a specific application. Depending on the specific requirements, the MSP[®] dehumidifier is equipped with a fan meeting the required SRC standard.

▶ Key Benefits & Features

- **Safe** critical electrical components are outside the explosive environment
- **Reliable** Simple Technology, No Moving Parts, Low Maintenance
- **Performs** Delivers consistent low dew-point temperatures
- **Sanitary** Full Draining, No Standing Water
- **Efficient** Cuts dehumidification operating costs by up to 50%
- **Fast ROI** Lower capital costs, Competitively priced
- **Versatile** Chilled Water and Refrigerant units
- **Flexible** Horizontal, Vertical and Modular configurations
- **State of the Art** Cutting-Edge Control Systems

DEHUMIDIFIER WITH MSP[®] TECHNOLOGY

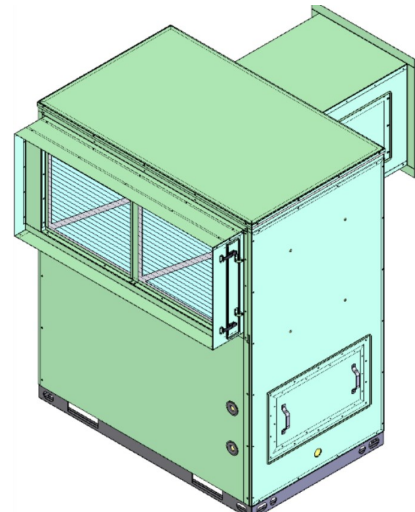

ABOUT MSP® DEHUMIDIFICATION TECHNOLOGY

MSP® Dehumidification Technology is offered in a wide range of super-efficient, industrial grade dehumidification equipment under the MSP Technology brand, and others. Designed specifically for green applications, MSP products are engineered for high performance, guaranteed.

SOME APPLICATIONS FOR MSP TECHNOLOGY

CONDENSATION CONTROL

Supermarkets • Indoor Ice Rinks • Water Treatment
Wastewater Treatment Facilities

INDUSTRIAL DRYING

Leather • Food Drying • Paper Production
Investment Casting • Lumber

PRESERVATION

Dry Storage Warehouses • Paper Storage
Museums • Archives • Libraries • Film Storage

EXPLOSIVE & FLAMMABLE ENVIRONMENTS

Paint Spray Booths • Military • Munitions Storage

CRITICAL ENVIRONMENT

Semiconductor Manufacturing • Pharmaceuticals
Health Care • Laboratories • Clean Rooms

INDOOR FARMING

Produce • Medical Marijuana

ATMOSPHERIC WATER GENERATION

OUR CLIENTS INCLUDE



and many more...

HOW IT WORKS

MSP® DEHUMIDIFICATION AND ATMOSPHERIC WATER GENERATION TECHNOLOGY

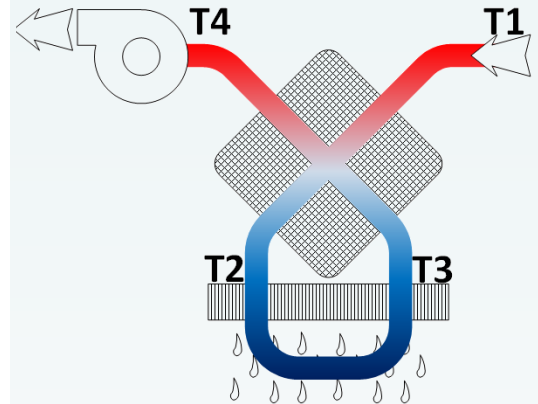

STEP 1 Warm, humid incoming air (T1) flows through the first pass of the plate type air-to-air heat exchangers for pre-cooling and initial condensing and water production. This is accomplished by regenerative thermal exchange with the cooler air that is leaving the heat exchanger. (see step 3)

Advantage: Pre-cooling, condensing and water production by regenerative thermal exchange are "free" and involve no additional equipment.

STEP 2 Pre-cooled air (T2) then passes twice over conventional cooling coils for final cooling, condensing and water production

Advantage: Pre-conditioned air can be treated much more efficiently, using smaller compressors that require as little as one-half the power.

STEP 3 The cool, now dry air (T3) is then drawn back through the opposite side of the heat exchanger where it absorbs some heat from incoming air (see step 1) and continues on to possibly serve a secondary purpose.

Advantage: No heating coil—and no energy penalty—needed to reheat the dehumidified air before it enters the conditioned environment.