

LOW COST WATER WHERE ITS NEEDED MOST



An Atmospheric Water Generator (AWG) is simply a mechanical dehumidifier whose water is harnessed for human consumption, or grey water such as irrigation, flushing and other useful purposes. Dehumidified air is a secondary feature that may be used to provide fresh low humidity outdoor air to an enclosed environment.

This high tech state of the art machine is perfect for producing water in areas where it may be scarce. It is also a great resource for dry climates dealing with year-round high temperatures and extreme humidity where water sources are scarce. However, it is especially useful in developing areas lacking a clean drinking water resources available.

MSP Technology's Atmospheric Water Generator can help reduce your 'carbon footprint' and achieve an ecological and economical answer to the world's ever increasing water crisis.

▶ Key Benefits & Features

- **High Performance:** Delivers consistent low dew-point temperatures
- **High Efficiency:** Precools incoming air, cuts operating costs up to 50%
- **Simple Technology:** Simple technology, familiar to HVAC contractors and technicians
- **Reliable:** No moving parts in the airstream, except direct drive fan.
- **Low Maintenance:** Direct drive Fans, no belts or pulleys to adjust.
- **Sanitary:** Full draining, no standing water
- **Fast ROI:** Lower capital costs, competitively priced
- **Flexible:** Horizontal and vertical airflow configurations
- **Versatile:** Available using chilled water or refrigerant

ATMOSPHERIC WATER GENERATOR
WITH MSP® TECHNOLOGY

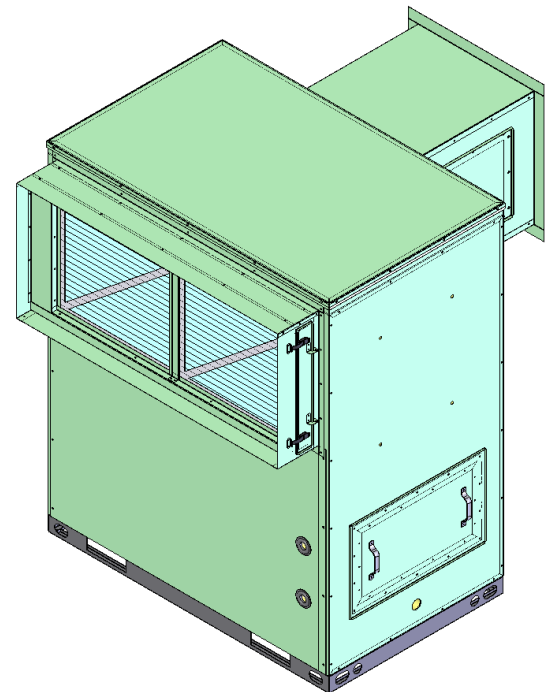

ABOUT MSP TECHNOLOGY

MSP Technology is offered in a wide range of super-efficient, industrial grade dehumidification and Atmospheric Water Generation (AWG) equipment. Designed specifically for green applications, MSP products are engineered for high performance, guaranteed.

APPLICATIONS FOR MSP TECHNOLOGY

Condensation Control

Supermarkets • Indoor Ice Rinks • Refrigerated Warehouses
Telecommunications Centers • Switching Stations • Pumping Stations • Power Plants • Well Houses

Product Drying

Leather Drying • Food Drying • Paper and Pulp Production • Investment Casting Drying • Lumber Drying

Product Preservation

Dry Storage Warehouses • Printing and Paper Storage • Museums /Archives • Libraries • Film Storage

Critical Environment

Semiconductor Manufacturing • Pharmaceutical Manufacturing Operating Rooms • Laboratories • Clean Rooms

OUR CLIENTS INCLUDE



and many more...

MSP® DEHUMIDIFICATION & AWG TECHNOLOGY

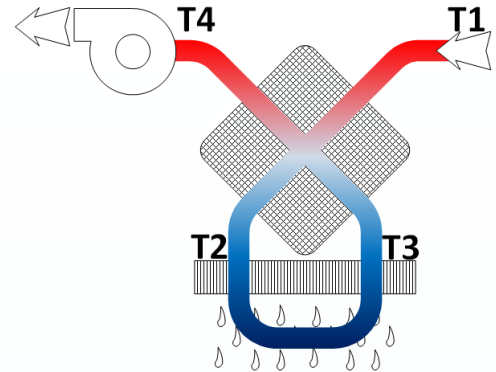

STEP 1: Warm, humid incoming air (T1) flows through the first pass of the plate heat exchangers for initial pre-cooling, water production and dehumidification. This is accomplished by regenerative thermal exchange with the cooler air that is leaving the heat exchanger. (See step 3)

Advantage: Up to 80% Pre-cooling—water production and dehumidification, by regenerative thermal exchange, is "free" and involves no additional equipment. MSP has no moving parts and is driven by either chilled water or refrigeration systems.

Comparison: Traditional Dehumidifiers "require" hot-gas re-heating, with no precooling and therefore no energy savings.

STEP 2: Pre-cooled air (T2) then passes twice over a conventional cooling coil for final cooling, dehumidification and water production.

Advantage: Pre-cooling reduces the energy load on the cooling coil so dehumidification and water production are achieved at a low rate of energy consumption, using smaller compressors that require as little as one-half the power.

Comparison: Traditional dehumidifiers have no precooling and therefore no energy savings.

STEP 3: The cool, condensed and dehumidified air (T3) is drawn through the opposite side of the heat exchanger where it is heated by transfer with incoming air (see step 1) and advances to supply dry air that may be used for mold and mildew mitigation.

Advantage: No heating coil—and no energy penalty—needed to heat the dehumidified air before it enters the conditioned environment. Water production is accomplished simultaneous with supplying dry air for mitigating mold and mildew.

Comparison: Traditional dehumidifier uses hot gas reheating which requires a refrigeration system. MSP, on the other hand will operate effectively with chilled water or refrigeration.