

MSP[®] TECHNOLOGY IS SIMPLY THE MOST EFFICIENT HUMIDITY CONTROL SOLUTION FOR DRY STORAGE FACILITIES

Cost Effective Protection for your Valuable Goods



Dry Storage facilities require dehumidification for the protection of stored goods from mold, mildew, rot and corrosion. Applications range from military aircraft storage to agricultural bulk storage of grains, sugar and fertilizer and many more.

MSP[®] Dehumidification is the most cost effective and efficient method to properly maintain and protect goods in a Dry Storage Facility. The adverse effects of corrosion, mold and mildew growth are controlled by maintaining humidity in a dry storage facility. Multiple Small Plate (MSP[®]) technology, is the most energy efficient dehumidification solution available in this application. MSP uses up to 50% less energy than competitive systems. In addition MSP is highly reliable with very low maintenance and **No Moving Parts** in the air stream, with the exception of a beltless, low maintenance, fan.

▶ Key Benefits & Features

- **Reliable** Simple Technology, No Moving Parts, Low Maintenance
- **Performs** Delivers consistent low dew-point temperatures
- **Sanitary** Full Draining, No Standing Water
- **Efficient** Cuts dehumidification operating costs by up to 50%
- **Fast ROI** Lower capital costs, Competitively priced
- **Versatile** Chilled Water and Refrigerant units
- **Advanced** Single unit provides dehumidification, sensible cooling, heating and ventilation air
- **Flexible** Horizontal, Vertical and Modular configurations for uses with space or access issues

DEHUMIDIFIER WITH MSP[®]TECHNOLOGY

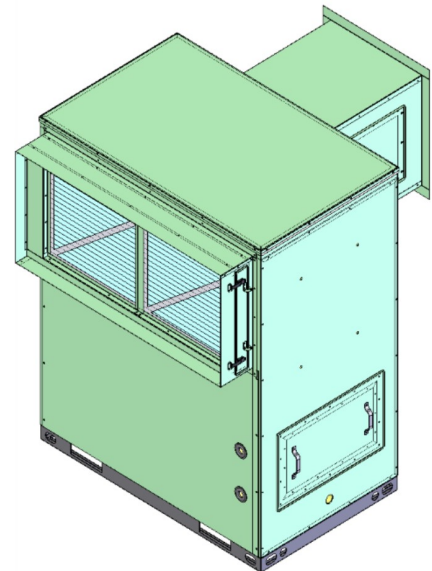

ABOUT MSP® DEHUMIDIFICATION TECHNOLOGY

MSP® Dehumidification Technology is offered in a wide range of super-efficient, industrial grade dehumidification equipment under the MSP Technology brand, and others. Designed specifically for green applications, MSP products are engineered for high performance, guaranteed.

SOME APPLICATIONS FOR MSP TECHNOLOGY

CONDENSATION CONTROL

Supermarkets • Indoor Ice Rinks • Water Treatment
Wastewater Treatment Facilities

INDUSTRIAL DRYING

Leather • Food Drying • Paper Production
Investment Casting • Lumber

PRESERVATION

Dry Storage Warehouses • Paper Storage
Museums • Archives • Libraries • Film Storage

EXPLOSIVE & FLAMMABLE ENVIRONMENTS

Paint Spray Booths • Military • Munitions Storage

CRITICAL ENVIRONMENT

Semiconductor Manufacturing • Pharmaceuticals
Health Care • Laboratories • Clean Rooms

INDOOR FARMING

Produce • Medical Marijuana

ATMOSPHERIC WATER GENERATION

OUR CLIENTS INCLUDE



and many more...

HOW IT WORKS

MSP® DEHUMIDIFICATION AND ATMOSPHERIC WATER GENERATION TECHNOLOGY

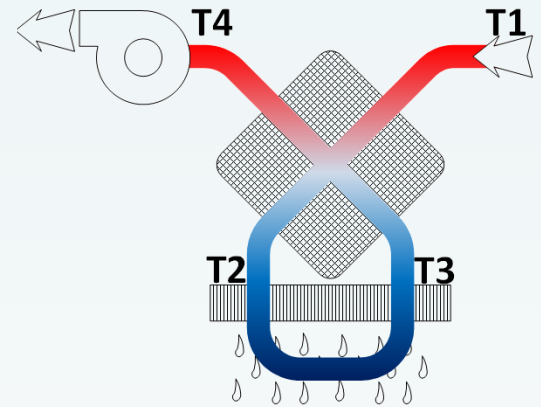

STEP 1 Warm, humid incoming air (T1) flows through the first pass of the plate type air-to-air heat exchangers for pre-cooling and initial condensing and water production. This is accomplished by regenerative thermal exchange with the cooler air that is leaving the heat exchanger. (see step 3)

Advantage: Pre-cooling, condensing and water production by regenerative thermal exchange are "free" and involve no additional equipment.

STEP 2 Pre-cooled air (T2) then passes twice over conventional cooling coils for final cooling, condensing and water production

Advantage: Pre-conditioned air can be treated much more efficiently, using smaller compressors that require as little as one-half the power.

STEP 3 The cool, now dry air (T3) is then drawn back through the opposite side of the heat exchanger where it absorbs some heat from incoming air (see step 1) and continues on to possibly serve a secondary purpose.

Advantage: No heating coil—and no energy penalty—needed to reheat the dehumidified air before it enters the conditioned environment.